

EXCELL LIFT

4500 KG 2 POST HOIST

The Excell 4500 kg Hydraulic Two Post Lift is a professional grade solution designed to make vehicle servicing safer, faster, and more efficient. It accommodates a wide range of vehicles, from compact cars to large SUVs. Built in safety features such as mechanical locks, synchronized safety ropes, and manual single point release provide maximum stability and operator protection.

Easy to maintain and simple to operate, this lift is the perfect combination of reliability, durability, and precision for any professional automotive workshop requiring light commercial use.

MAIN FEATURES

- 4500kg lifting capacity
- Single and 3 phase options
- 4WD adapters included (Savings of \$720.00)
- Manual single point lock release
- Black powder coating with red safety arms
- 3 stage front + 2 stage rear lifting arms with telescopic range up to 1350mm
- Twin hydraulic cylinders
- Wide vehicle compatibility (most)
- SUV compatibility (most)
- WorkSafe plant design registration number WSV-0151533670

ADDITIONAL BENEFITS

- Fast installation with clear instructions.
- Easy maintenance: grease points, adjustable balance ropes, and straightforward hydraulic checks.
- Designed for trained operators to lift vehicles safely and efficiently.



**TRUSTED BY KANGAN INSTITUTE
AUTOMOTIVE CENTRE OF EXCELLENCE**

CONCRETE

150mm thick, reinforced, free from cracks/seams, 30mpa & cured 28+ days

SPECIFICATIONS

Model No.	LOGEXCELL
Lifting Capacity (kg)	4,500kg
Min. Lifting Height (mm)	95mm
Max. Lifting Height (mm)	1,990mm
Lifting Time	40-50 sec
Lowering Time	30-40s
Operating Method	Control Box
Overall Height	3900mm
Power Supply	220V/415V 15amp (Single & 3 Phase)

**WATCH THIS VIDEO FROM A
TRUSTED HOIST INSTALLER**



LAYOUT

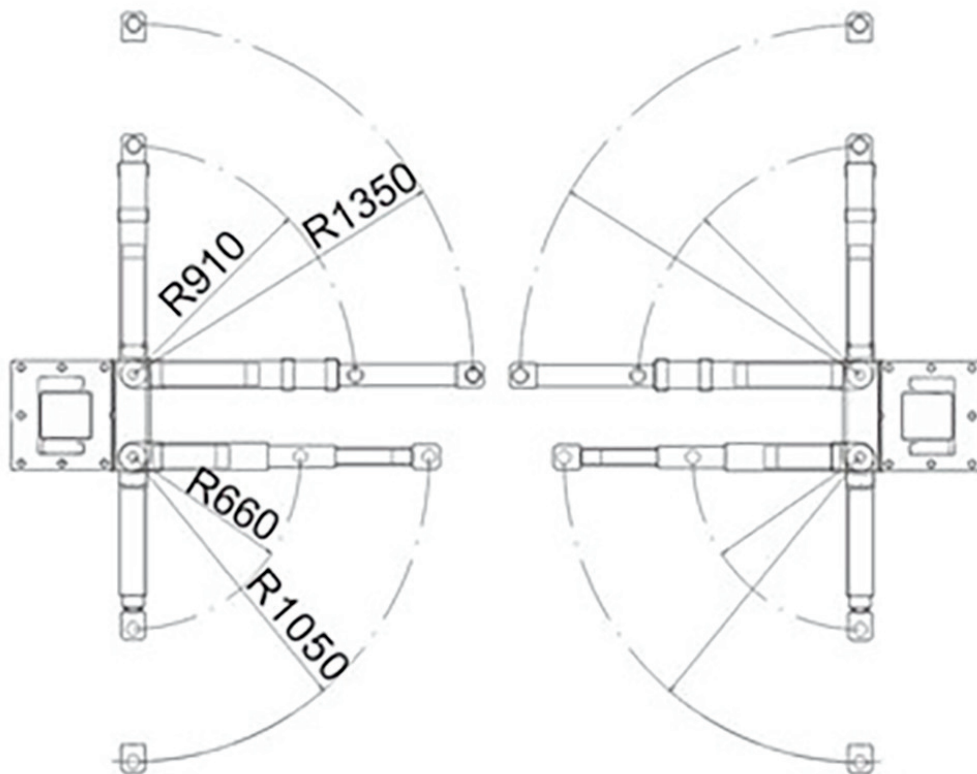
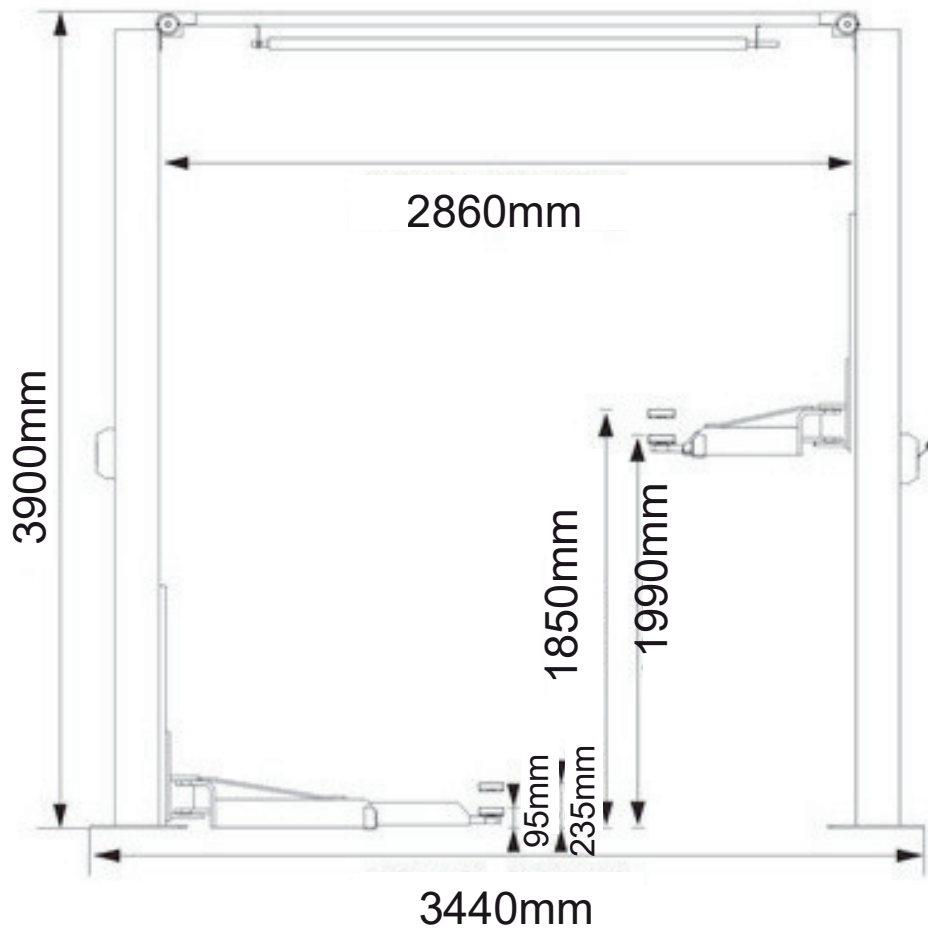

Specifications/images subject to change without prior notice. To validate warranty, proof of valid maintenance contract is required. Images and illustrations are indicative and may be modified without notice.